



**Glendora, California**

Toll-Free: 800.735.5566

Phone: 909.592.6272

Fax: 909.592.7971

**Roscommon, Ireland**

Phone: 35.39.03.25922

Fax: 35.39.03.25921

# M Series G3048-18

## Medium Duty

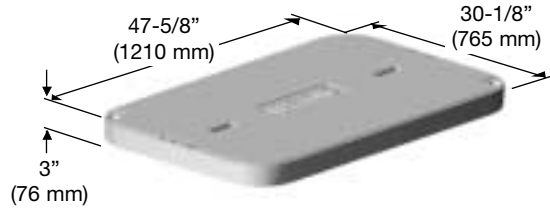

**Cover**

Material: Polymer Concrete

Weight: 243.0 lbs. (110.2 kg)

Model: G3048-PR

See *OPTIONS SECTION*:

– *Light Weight Cover*

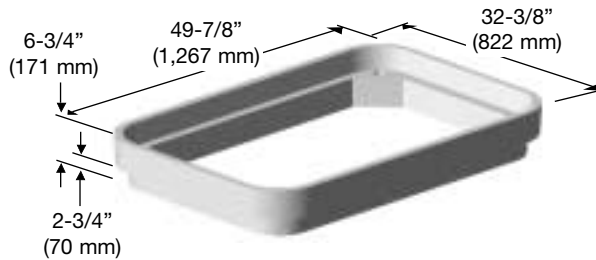

**Ring**

Material: Polymer Concrete

Weight: 118.0 lbs. (53.5 kg)

Model: G3048-PR

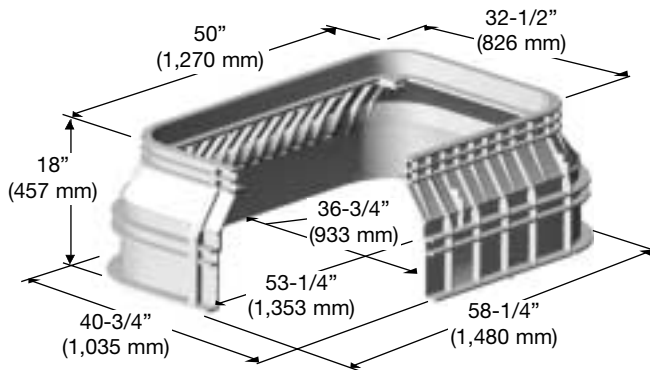

**Body –**  
Made to order

**Body**

Material: GF-HDPE

Weight: 59.0 lbs. (26.7 kg)

Model: G3048-18

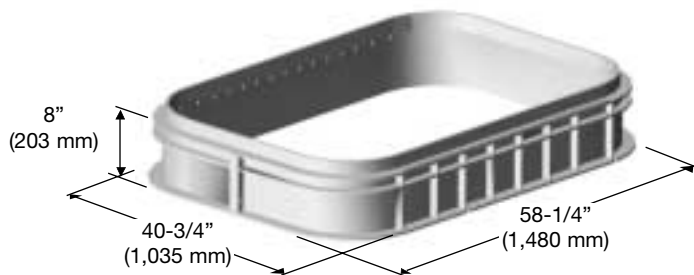

**Extension –**  
Made to order

**Extensions**

Material: GF-HDPE

– 8" Weight: 25.0 lbs. (11.3 kg)

Model: G3048-8X

**Color Available**

Gray

Note: For use in non-vehicular traffic situations only. Weights and dimensions may vary slightly.

Revision Date 4/2003

# M Series G3048-18

## Medium Duty

## Carson Industries, LLC

### Glendora, California

Toll-Free: 800.735.5566

Phone: 909.592.6272

Fax: 909.592.7971

### Roscommon, Ireland

Phone: 35.39.03.25922

Fax: 35.39.03.25921

### Static Vertical Load Rating

(Design Load; Test Load)

- Tier 5 – 5,200 lbf; 11, 282 lbf
- WUC, Guide 3.6 – 10,400 lbf; Report Ultimate

### Shipping Configuration

- Unit, 3 assemblies,  
= 57.0 cu. ft., 802.0 lbs.

Properties of Base Material	ASTM Test Method	HDPE
Tensile Strength	D-638	2,700-4,400 psi (Typical Range)
Flexural Modulus	D-790	Min. 140,000 not to exceed 240,000 psi
Notched Izod Impact Strength	D-256	0.5-3.0 (Typical Range)
Deflection Temperature @ 66 PSI	D-648	150° to 200° F. (Typical Range)
Density	D-792	Min 0.950 not to exceed 0.965
Electrical Dielectric Strength	D-149	400-600 V/mil (Typical Range)

### Molded Product

Chemical Resistance	D-543	Very Resistant*
Water Absorption	D-570	Less than 1% weight change*

\*Test reports available on request

### Properties of Polymer Concrete Material

Flexural Strength	C-580	1,800 psi
Compression Strength	C-579	11,000 psi

### Shipping Information

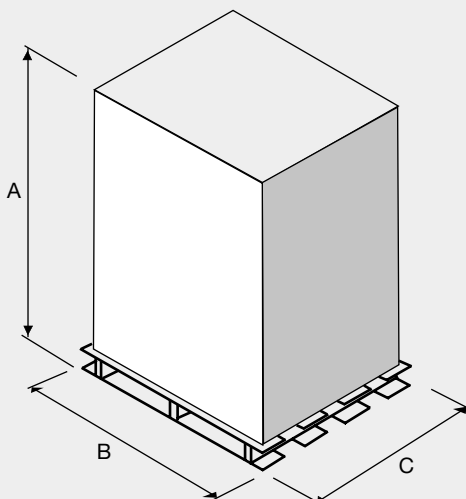

UNIT			COVER			RING		
Dim.	Description	Value	Dim.	Description	Value	Dim.	Description	Value
A	Height	83"	A	Height	36"	A	Height	45"
B	Length	42"	B	Length	42"	B	Length	42"
C	Width	60"	C	Width	48"	C	Width	54"

**Units:** 3 per pallet  
**Weight:** 1,867 lbs. per pallet

**Units:** 10 per pallet  
**Weight:** 2,475 lbs. per pallet

**Units:** 10 per pallet  
**Weight:** 1,230 lbs. per pallet

BODY		
Dim.	Description	Value
A	Height	83"
B	Length	42"
C	Width	60"

**Units:** 3 per pallet  
**Weight:** 409 lbs. per pallet

Note: For use in non-vehicular traffic situations only. Weights and dimensions may vary slightly.

All information contained in this brochure was current at the time of printing. Because of Carson Industries' policy of ongoing research and development, the Company reserves the right to discontinue or update product information without notice.