



Glendora, California

Toll-Free: 800.735.5566

Phone: 909.592.6272

Fax: 909.592.7971

Roscommon, Ireland

Phone: 35.39.03.25922

Fax: 35.39.03.25921

H Series HLW1212

Light Weight

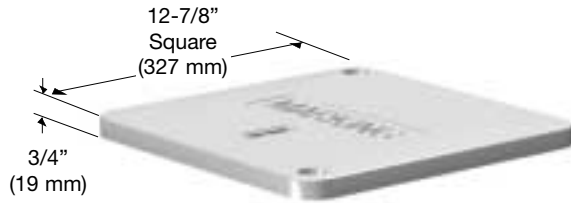

Cover¹

Material: Polymer Concrete

Weight: 10.0 lbs. (4.5 kgs)

Model: HLW1212-P0

Skid Resistant Surface²
(Material compliant with WUC, Guide 3.6³)

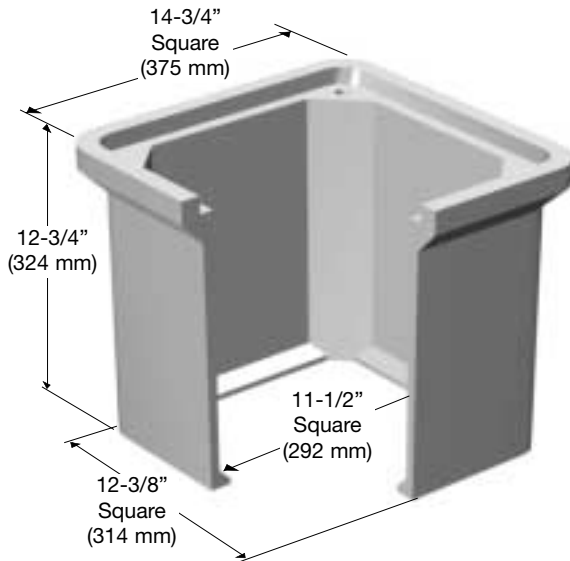

Body

Material: Polymer Concrete

Weight: 32.0 lbs. (14.5 kgs)

Model: HLW1212-12

Tolerances

Cover $\pm 1/8$ " (3 mm);

Body $\pm 1/8$ " (3 mm)

Foot $\pm 1/16$ " (2 mm);

Height $\pm 1/4$ " (6 mm)

Fasteners: 2 each (optional 4 ea) 3/8-16 UNC, Stainless Steel, Hex Head with Washer; Options: size, quantity, type head
Cover Identification is blank unless specified

Steel Covers Optional

Boxes are stackable. Vertical load ratings are stated for single boxes. For units with MOLDED OPENINGS, subtract 2 lbs from Unit Weight. Weights may vary slightly. Dimensions in inches with metric equivalents.

H Series HLW1212

Light Weight

Carson Industries, LLC

Glendora, California
Toll-Free: 800.735.5566
Phone: 909.592.6272
Fax: 909.592.7971

Roscommon, Ireland
Phone: 35.39.03.25922
Fax: 35.39.03.25921

Vertical and Lateral Load Rating *(Design Load; Test Load)*

All "H Series" Bodies and Covers

- C857 A-8, AASHTO, HS10-44 – 8,000 lbf; 22, 880 lbf
- SCTE Tier 10 – 10,400 lbf; 22, 568 lbf

Shipping Configuration

- **Single Bodies – 12.75":**
Unit. 45 assemblies,
= 62.0 cu. ft.; 1,512.0 lbs.

Standard Test Method	Properties of Raw Material	ASTM Designation	Test Results
Compressive Strength of Polymer Concretes	Compressive Strength	C 579-96	11,000 psi
Flexural Strength and Modulus of Elasticity of Polymer Concretes	Flexural Strength Modulus of Elasticity	C 580-93	1,800 psi 2,900,000 psi
Chemical Resistance of Polymer Concretes	Chemical Resistance	C 267-97	Pass ⁴
Determination of Impact Resistance by means of a Tup (falling weight)	Impact Resistance	D 2444-93	Pass

¹AASHTO H-10, ASTM C 857, A-8, 8,000 lbs Design Load. Static Vertical Load Rating >22,880 lbf. SCTE Tier 10, 10,400 lb design load; 22,568 lbf minimum test load.

²Coefficient of Friction (ASTM C1028) >0.5

³Western Underground Committee, Guide 3.6

⁴Specimens exposed to ten reagents (alkalis, acids and petroleum distillates) experience <2% weight and dimensional change and retain >75% of average Compressive Strength. Listing of reagents and test reports available upon request.

Shipping Information

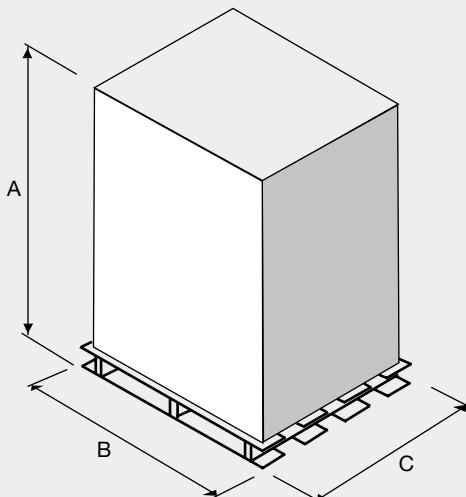

UNIT			COVER			BODY		
Dim.	Description	Value	Dim.	Description	Value	Dim.	Description	Value
A	Height	70"	A	Height	24"	A	Height	65"
B	Length	42"	B	Length	42"	B	Length	42"
C	Width	48"	C	Width	48"	C	Width	48"

Units: 45 per pallet
Weight: 1,485 lbs. per pallet

Units: 180 per pallet
Weight: 1,845 lbs. per pallet

Units: 45 per pallet
Weight: 1,485 lbs. per pallet

All information contained in this brochure was current at the time of printing. Because of Carson Industries' policy of ongoing research and development, the Company reserves the right to discontinue or update product information without notice.